

### Illustration

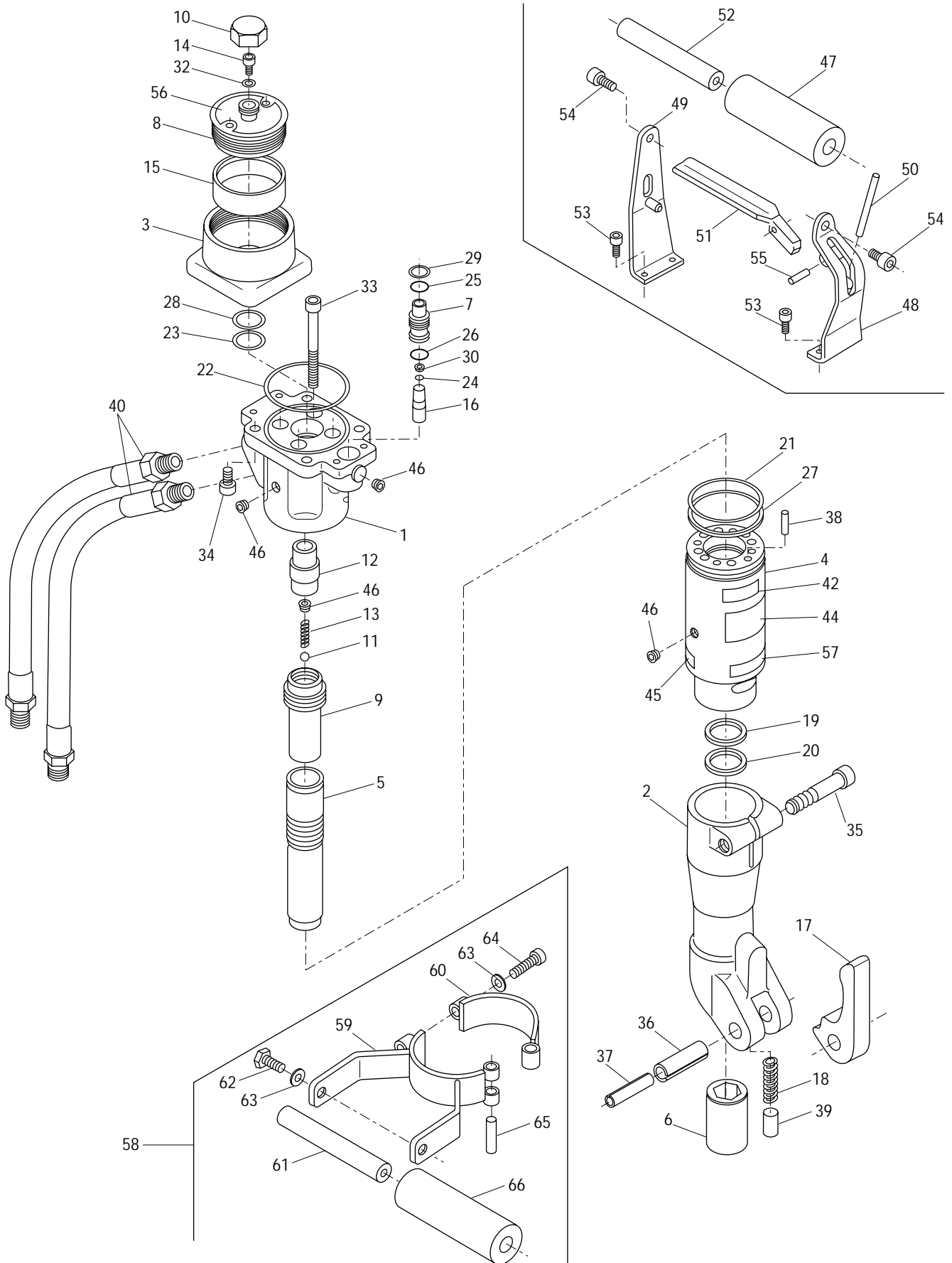

## Parts List

Key	UPC No. 78-3310-	Part No.	Description	Qty
1	45941	504 5941.1	Valve body .....	1
2	45942	504 5942.2	Front end .....	1
3	45943	504 5943.0	Shell .....	1
4	45944	504 5944.9	Cylinder .....	1
5	45945	504 5945.7	Piston .....	1
6	45945	504 5946.5	Chisel bushing .....	1
7	45946	504 5947.3	Valve guide .....	1
8	45948	504 5948.1	Lid .....	1
9	45949	504 5949.0	Inner tube .....	1
10	45950	504 5950.3	Cap .....	1
11*	45951	504 5951.1	Steel ball .....	1
12	45952	504 5952.0	Control valve .....	1
13*	45953	504 5953.8	Spring .....	1
14	45954	504 5954.6	Cap bolt .....	1
15	45955	504 5955.4	Diaphragm .....	1
16	45956	504 5956.2	Valve rod .....	1
17	45957	504 5957.0	Latch (1") .....	1
18	45958	504 5958.9	Lock spring .....	1
19*	45959	504 5959.7	U-cup packing .....	1
20*	45960	504 5960.0	Dust seal .....	1
21*	45961	504 5961.9	O-ring, G60 .....	1
22*	45962	504 5962.7	O-ring, S70 .....	1
23*	45963	504 5963.5	O-ring, P22 .....	1
24*	45964	504 5964.3	O-ring, P5 .....	1
25*	45965	504 5965.1	O-ring, P14 .....	1
26*	45966	504 5966.0	O-ring, P12.5 .....	1
27*	45967	504 5967.8	Backup ring, G60 .....	1
28*	45968	504 5968.6	Backup ring, P22 .....	1
29*	45969	504 5969.4	Backup ring, P14 .....	1
30*	45970	504 5970.8	Backup ring, P5 .....	1
32*	45972	504 5972.4	Seal washer .....	1
33	45973	504 5973.2	Bolt, hex socket, 8x80 .....	4
34	45974	504 5974.0	Bolt, hex socket, 8x15 .....	4
35	45975	504 5975.9	Bolt, hex socket, 10x50 .....	1
36	45976	504 5976.7	Spring pin, Ø16x50 .....	1
37	45977	504 5977.5	Spring pin, Ø10x50 .....	1
38	45978	504 5978.3	Spring pin, Ø6x20 .....	1
39	45979	504 5979.1	Needle roller .....	1
40	45980	504 5980.5	Hydraulic hose, 3/8 NPTF x 3/8 NPTF .....	2
42		500 1746.2	Decal, identification .....	1
44		49009	Decal, warning .....	1
46	45983	504 5983.0	Taper plug, hex socket PT1/8 .....	10
47	45984	504 5984.8	Handle grip .....	1
48	45985	504 5985.6	Handle stay .....	1
49	45986	504 5986.4	Handle stay .....	1
50	45987	504 5987.2	Push rod .....	1
51	45988	504 5988.0	Control lever .....	1
52	45989	504 5989.9	Handle pipe .....	1
53	45990	504 5990.2	Bolt, hex socket, 6x15 .....	4
54	45974	504 5974.0	Bolt, hex socket, 8x15 .....	2
55	45992	504 5992.9	Spring pin, Ø5x22 .....	1
56	46197	504 6197.4	Decal, caution .....	1
57	45898	504 5898.1	Decal, pressure / flow / weight .....	1

Key	UPC No. 78-3310-	Part No.	Description	Qty
58	46258	504 6258.0	Handle, side (includes items 59-66)	
59	46254	504 6254.7	Bracket, handle, top half .....	1
60	46255	504 6255.5	Bracket, handle, bottom half .....	1
61	46256	504 6256.3	Pin, center .....	1
62	46257	504 6257.1	Bolt, 8 mm x 35 mm .....	2
63	46259	504 6259.8	Washer, handle .....	3
64	46262	504 6262.8	Bolt, handle .....	1
65	46264	504 6264.4	Pin, bracket .....	1
66	46261	504 6261.0	Grip, handle .....	1

### Kits

46296	504 6296.2	Kit, seal (includes items marked with an asterisk)
-------	------------	--

### Accessories

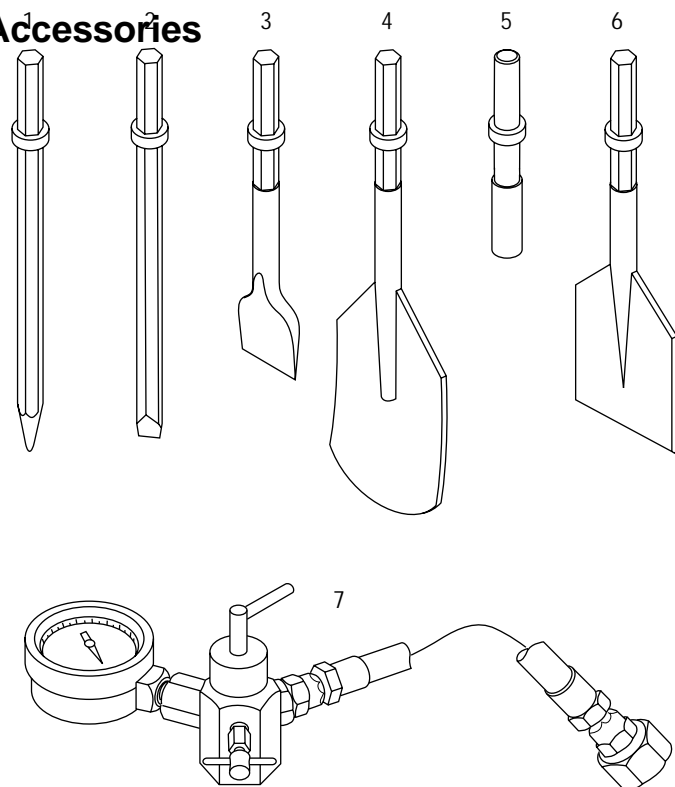

Key	UPC No. 78-3310-	Part No.	Description
1	41610	F016769	Moil point
2	46260	504 6260.1	Chisel bit, 1-3/8"
3	46253	504 6253.9	Chisel bit, 3"
4	46289	504 6289.0	Clay spade
5	46222	504 6222.9	Rod driver (for 5/8" maximum diameter ground rod)
	46223	504 6223.7	Rod driver (for 1" maximum diameter ground rod)
6	46288	504 6288.1	Asphalt cutter
7	46251	504 6251.2	Accumulator charging valve